

Product Description:

- High performance small square type photoelectric sensor, standard mounting aperture 25.4mm
- 65mm BGS diffuse, suitable for applications such as mask machines, ATM machines, logistics transportation, new energy, etc.

Product features:

- 65 mm BGS detection distance is adjustable
- Light on and dark on can be adjusted
- IP67 protection rating

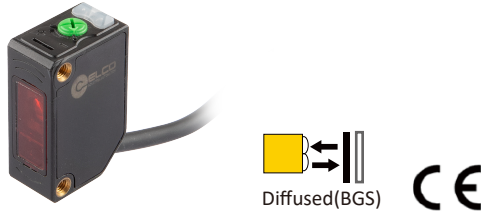

Type	Distance	Beam	Output	Connection	Wiring
OS10-AK65CN6 *M <sup>1)</sup>	6...65mm	Red	NPN	Cable	Fig.1
OS10-AK65CP6 *M <sup>1)</sup>	6...65mm	Red	PNP	Cable	Fig.2
OS10-AK65CN6Q8	6...65mm	Red	NPN	M8 Connector	Fig.3
OS10-AK65CP6Q8	6...65mm	Red	PNP	M8 Connector	Fig.4

Note 1): \* M refers to the cable length in meters. If there is no \* M in the model, the default cable length is 2 meters.

TECHNICAL SPECIFICATION

<b>OPERATING VOLTAGE</b>	10...30 V DC	<b>AMBIENT TEMPERATURE OPERATION</b>	-25°C...+55°C
<b>LIGHT SOURCE TYPE</b>	Red LED,625nm	<b>AMBIENT TEMPERATURE STORAGE</b>	-40°C...+70°C
<b>OUTPUT CHARACTERISTIC</b>	PNP/NPN	<b>CIRCUIT PROTECTION</b>	Short-circuit protection, reverse polarity protection, over-load protection
<b>LOAD CURRENT</b>	≤100mA	<b>PROTECTION DEGREE</b>	IP67
<b>SWITCHING FREQUENCY</b>	400Hz	<b>HOUSING MATERIAL</b>	PC+PBT,PMMA
<b>ADJUSTMENT OF OPERATING DISTANCE</b>	Potentiometer	<b>CONNECTING TYPE</b>	Cable /4-pin M8 connector
<b>SWITCH MODE SETTING</b>	WH:U+/blank Light on U- Dark on		
<b>LIGHT SPOT DIAMETER</b>	Approx.2mm at 20mm distance		

DIMENSIONS

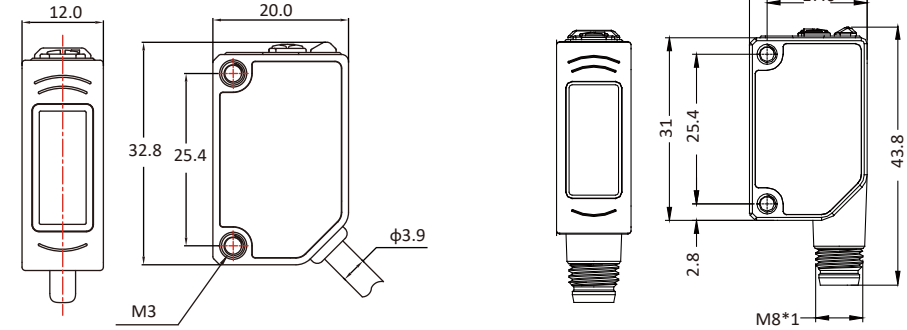

INDICATORS

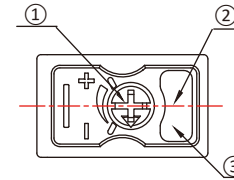

①	Detection distance adjuster	
②	Output indicator	Yellow
③	Stable indicator	Green

Scanning distance difference Curve (White 90%/black 6%)

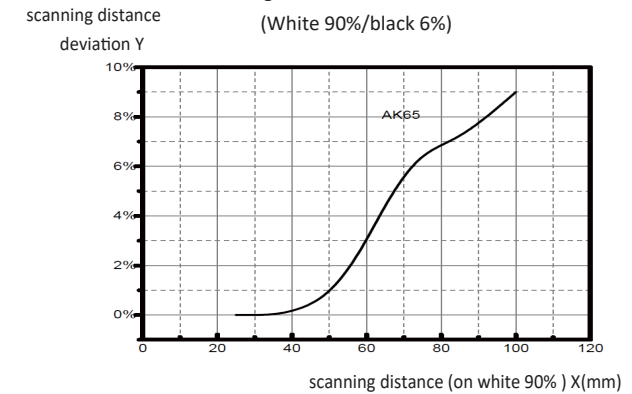

ELECTRICAL CONNECTION

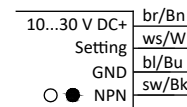

Fig.1

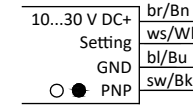

Fig.2

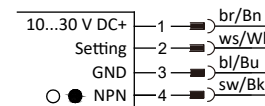
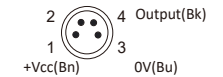

Fig.3

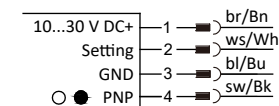

Fig.4

- = Light on: Connect the Setting to U+ or blank
- = Dark on: Connect the Setting to U-

产品说明:

- 高性能小方型光电传感器, 标准安装孔径25.4mm
- 65mm BGS漫反, 适用口罩机、ATM机、物流输送、新能源等应用。



产品特点:

- 65mm BGS 检测距离可调
- 亮暗通可调节
- IP67防护等级

型号	检测距离	光源	输出方式	连接方式	接线图
OS10-AK65CN6 *M <sup>1)</sup>	6...65mm	红光	NPN	线缆	图1
OS10-AK65CP6 *M <sup>1)</sup>	6...65mm	红光	PNP	线缆	图2
OS10-AK65CN6Q8	6...65mm	红光	NPN	M8 连接器	图3
OS10-AK65CP6Q8	6...65mm	红光	PNP	M8 连接器	图4

注1): \*M表示线缆长度, 单位米, 型号中无\*M默认线缆长度为2米。

技术参数

工作电压	10...30 V DC	工作温度	-25°C...+55°C
光源	红光 LED, 625nm	环境温度	-40°C...+70°C
输出特性	PNP/NPN	保护电路	短路保护 反极性保护 输出过载保护
负载电流	≤100mA	防护等级	IP67
开关频率	400Hz	外壳	PC+PBT, PMMA
检测距离调节	旋钮调节	连接方式	线缆 /M8 连接器
开关模式设置	白线: U+/悬空 亮通 U- 暗通		
光斑直径	约2mm (检测距离20mm处)		

外形尺寸

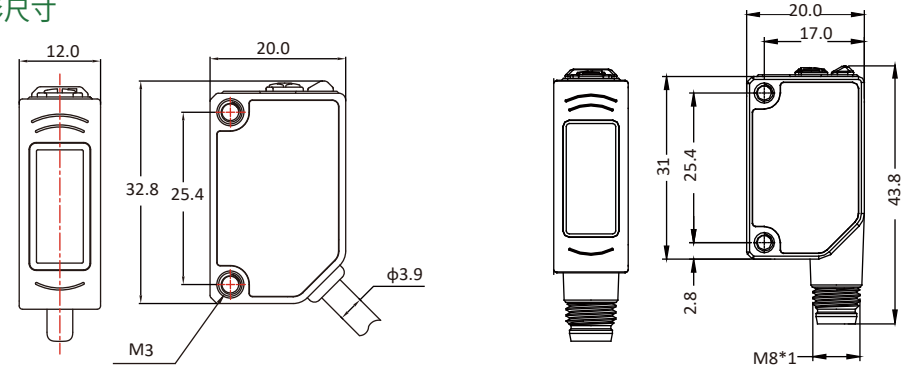

操作指示

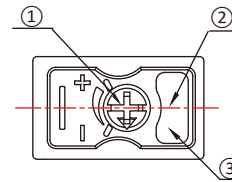

①	检测距离调节	
②	操作指示灯	黄色
③	电源指示灯	绿色

检测距离 Y  
偏差

检测距离差异曲线 (白90%/黑6%)

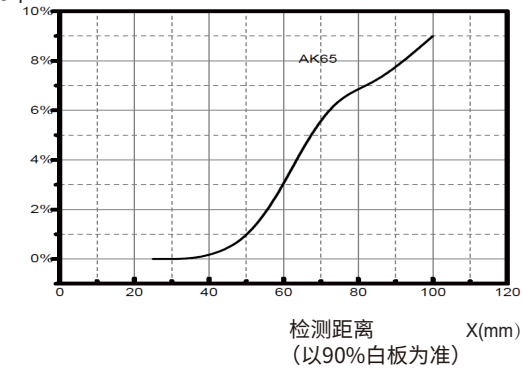

接线图

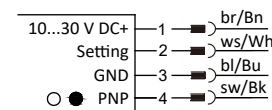
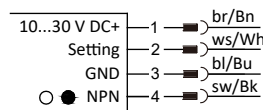
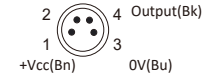
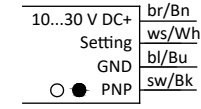
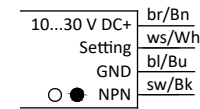

○ =亮通: Setting 接 U+或置空  
● =暗通: Setting 接 U-